

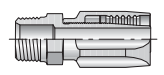



 <p>NPTF Pipe</p>	<p>20122 B-160</p>  <p>Male - Rigid</p>	 <p>JIC 37°</p>	<p>20622 B-160</p>  <p>Female - Swivel</p>	 <p>SAE 45°</p>	<p>20822 B-160</p>  <p>Female - Swivel</p>
 <p>Assembly Instructions</p>	<p>22 Series Assembly Instructions B-161</p>				



2 22
e F i e i g i

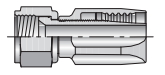

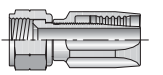
# rt er	re inch		se inch		inch		mm		iti n teri r ss	
20122-2-4	1/8x27	3/16	1.72	44	7/16	5/8	0.94	24		
20122-4-4	1/4x18	3/16	1.92	49	9/16	5/8	1.92	29	•	
20122-4-5	1/4x18	1/4	2.01	51	9/16	11/16	1.18	30	•	
20122-4-6	1/4x18	5/16	2.11	54	9/16	13/16	1.19	30	•	
20122-6-8	3/8x18	13/32	2.49	63	3/4	15/16	1.40	36	•	
20122-12-12	3/4x14	5/8	3.25	83	1-1/16	1-1/4	1.75	44	•	

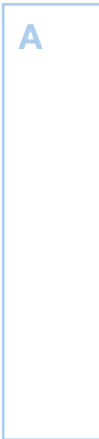
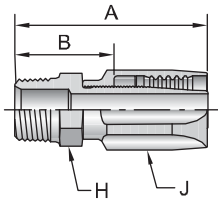
2 22
Fe e S i e

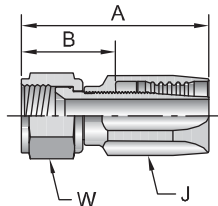

# rt er	re inch		se inch		inch		mm		iti n teri r ss	
20622-4-4~	1/4	7/16x20	3/16	1.74	44	5/8	9/16	0.96	24	•
20622-5-5~	5/16	1/2x20	1/4	1.91	49	11/16	5/8	1.08	27	•
20622-6-6	3/8	9/16x18	5/16	2.05	52	13/16	11/16	1.13	29	•
20622-8-8~	1/2	3/4x16	13/32	2.55	65	15/16	7/8	1.46	37	•
20622-10-10~	5/8	7/8x14	1/2	2.80	71	1-1/8	1	1.58	40	•
20622-12-12	3/4	1-1/16x12	5/8	3.15	80	1-1/4	1-1/8	1.65	42	•
20622-16-16	1	1-5/16x12	7/8	2.84	72	1-7/16	1-1/2	1.65	42	•
20622-20-20	1-1/4	1-5/8x12	1-1/8	3.00	76	1-3/4	2	1.72	44	•
20622-24-24	1-1/2	1-7/8x12	1-3/8	3.30	84	2	2-1/4	1.93	49	•
20622-32-32	2	2-1/2x12	1-13/16	4.05	103	2-1/2	2-7/8	2.31	59	•
20622-40-40	2-1/2	3x12	2-3/8	4.17	106	3-1/8	3-3/8	2.36	60	•

~These 20622 fittings contain a dual seat that accepts both the JIC (37°) and SAE (45°) male configurations. The -6 and -12 SAE (45°) swivel fittings are shown under part number 20822.

2 22
Fe e S i e

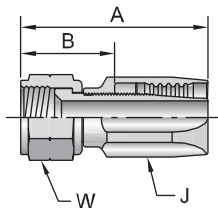

# rt er	re inch		se inch		inch		mm		iti n teri r ss	
20822-4-4	1/4	7/16x20	3/16	1.74	44	5/8	9/16	0.96	24	•
20822-5-5	5/16	1/2x20	1/4	1.91	49	11/16	5/8	1.08	27	•
20822-6-6	3/8	5/8x18	5/16	2.08	53	13/16	3/4	1.16	29	•
20822-8-8	1/2	3/4x16	13/32	2.45	62	15/16	7/8	1.36	35	•
20822-10-10	5/8	7/8x14	1/2	2.80	71	1-1/8	1	1.58	40	•
20822-12-12	3/4	1-1/16x14	5/8	3.10	79	1-1/4	1-1/4	1.60	41	•

Notch in nut for SAE (45°) flare.

22 Series

Assembly Instructions

1. Identify overall length (OAL) of hose assembly and the cut off allowance (COA) length of fitting(s) on hose ends by use of the fitting data table. Properly measure, mark and cut hose to desired length using fine tooth hacksaw or a cutoff machine. Care should be taken to ensure a square, clean cut is obtained. Air or solvent flush cut end of hose as necessary to produce a clean hose ID prior to assembly. Place socket in vice and screw in hose counter clockwise until hose bottoms. Back hose out 1/2 turn.
2. When assembling male pipe ends, slide nipple onto mandrel.
3. When assembling swivel ends, slide swivel nut over nipple. Slide nut and nipple onto mandrel. Screw mandrel threads into nipple and wrench tighten.
4. Oil inside of hose and nipple threads liberally with Hoze-Oil. (See Section C). NOTE
5. Push nipple into socket.
 - Male ends: Thread nipple in until it bottoms against socket.
 - Swivel ends: Thread nipple into socket using hex on assembly mandrel. Leave clearance of approximately 1/32" (.784mm) between nut and socket to allow nut to swivel. NOTE

Disassemble in reverse order.

Installation of these Fittings to the Hose

Inspection: Examine hose assembly internally for cut or bulged tube, obstructions and cleanliness. Clean ID of hose as necessary. Swivel nuts should turn freely. Check the layline of the hose to be sure the assembly is not twisted. Cap the ends of the assembly to keep clean.

Sealing: Oil inside of hose and nipple threads liberally with the same oil used in refrigeration system. NOTE Do not allow hose to contact any petroleum base fluids.

IF YOU HAVE QUESTIONS CONCERNING THE PRODUCTS OR APPLICATION OF THE PRODUCTS CONTAINED IN THIS CATALOG, PLEASE CALL: PARKER HOSE PRODUCTS DIVISION TECHNICAL SERVICES DEPARTMENT

PHONE: 440 / 943-5700

FAX: 440 / 943-3129

<http://www.parkerhose.com>

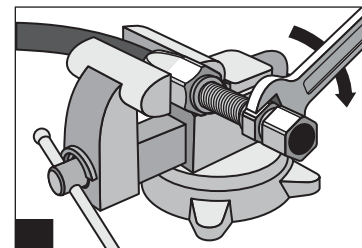
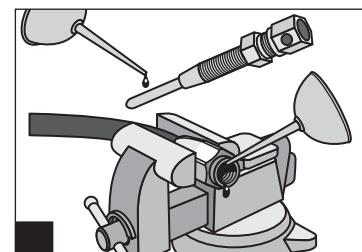
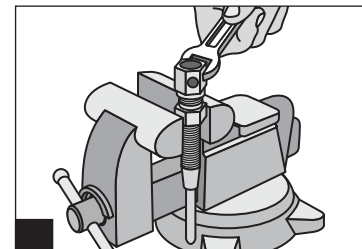
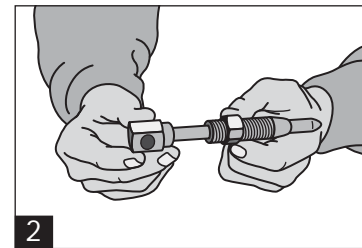
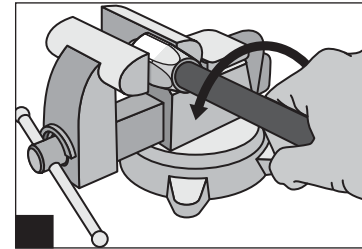

A

B

C

D

E